



ice line

**MIGEL**



**SERIE** **KFP**

**FABBRICATORI DI GHIACCIO GRANULARE PRESSATO**  
**MACHINES À GLACE EN GRAINS PRESSÉE**  
**ICE FLAKE MACHINES - PRESSED ICE FLAKES**  
**FABRICADORES DE HIELO GRANULAR PRENSADO**  
**EISFLOCKENBEREITER - GEPRESSTE EISFLOCKEN**

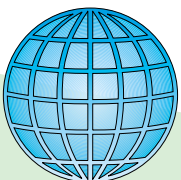

## Fabbricatori di ghiaccio granulare serie KFP



La gamma dei fabbricatori di ghiaccio granulare pressato della serie KFP è composta da 8 modelli con produzione giornaliera compresa tra i 78 Kg, 125 Kg e i 170 Kg con contenitore incorporato; ed i modelli modulari da 180 Kg, 275 Kg, 475 Kg, 900 Kg e 1700 Kg; fabbricatori modulari combinabili con i contenitori B/BL100, B/BL150, B/BL250 e TF60/RB60 o altri.

Il ghiaccio granulare pressato della serie KFP è ideale per l'uso nei bar, laboratori, ospedali, panifici, macellerie, peschierie, fast food e ristoranti.

Un ghiaccio granulare con una temperatura ottimale (-0,5°C) asciutto, compatto e non tende ad impaccarsi.

## Machines à glace en grains série KFP



La gamme de machines à glace en grains pressée série KFP est composée par 8 modèles avec une production journalière comprise entre 78 Kg, 125 Kg et 170 Kg, tous les deux avec le bac de conservation intégré; et les modèles modulaires de 180 Kg, 275 Kg, 475 Kg, 900 Kg et 1700 Kg; machines à glace en grains modulaires pour combinaison avec les bacs de conservation B/BF100, B/BF150, B/BF250 et TF60/RB60 ou d'autres.

La glace en grains pressée serie KFP est idéale pour bar, laboratoires, hôpitaux, boulangeries, boucheries, poissonneries, Fast Food et restaurants.

Une glace en grains avec une température idéale (-0,5°C), sèche, compacte qui ne s'empâte pas.

## Ice flake machines series KFP



The range of ice flake machines series KFP-pressed ice flakes consists of 8 models with a daily production between 78 Kg/172 Lb, 125 Kg/275 lb and 170 Kg/374 Lb all with built in storage bin; and the modular models 180 Kg/396 Lb, 275 Kg/510 Lb, 475 Kg/1045 Lb 900 Kg/1980 Lb and 1700 Kg/3740 Lb; modular ice-flake machines to combine with the storage bin B/BF100, B/BF150, B/BF250 and TF60/RB60 or others.

The pressed ice flake of series KFP is ideal for bar, laboratories, hospitals, bakeries, butchers, fishmongers, Fast Food outlets and restaurants.

An ice flake with a perfect temperature (-0,5°C) produced dry and compact.

## Fabricadores de hielo granular serie KFP



La gama de fabricantes de hielo granular prensado serie KFP está compuesta por 8 modelos con producción diaria comprendida entre 78 Kg, 125 Kg y 170 Kg con depósito incorporado; y los modelos modulares de 180 Kg, 275 Kg, 475 Kg, 900 Kg y 1700 Kg; modulares combinables con los depósitos B/BF100, B/BF150, B/BF250 y TF60/RB60.

El hielo granular prensado ideal para bar, laboratorios, hospitales, panificadores, carnicerías, pescaderías, Fast Food y restaurantes. El hielo granular es seco, compacto, con tendencia a no comprimirse y con temperatura óptima (-0,5°C).

## Eisflockenbereiter Serie KFP



Die Produktgruppe der Eisflockenbereiter Serie KFP gepresste Eisflocken besteht aus 8 Modellen mit Tagesleistungen von 78 Kg, 125 Kg und 170 Kg, mit eingebautem Behälter; und den Modulen, 180 Kg, 275 Kg, 475 Kg, 900 Kg und 1700 Kg; Bereiter im Modulbausystem kombinierbar mit den Behältern B/BF100, B/BF150, B/BF250 und TF60/RB60 oder anderen.

Die gepresste Eisflocke der Serie KFP ist ideal für den Gebrauch in Bar, Laboratorien, Krankenhäusern, Bäckereien, Fleischereien, Fischhandel, Fast Food und Restaurants. Eine Eisflocke mit einer optimalen Temperatur (-0,5°C), trocken, kompakt und nicht matschig.

## Caratteristiche Generali

- Produzione continua
- Carrozzeria in acciaio inox (AISI 304)
- Raffreddamento ad aria (A) o ad acqua (W)
- KF85 con ventilazione frontale per l'incasso a richiesta (Mod. F)
- Interruttore generale (ON/OFF)
- Trasmissione a cinghia KF 45/85/145/185
- Controllo elettronico del funzionamento (Modulari)
- Filtro (Modulari)
- Motoriduttore (Modulari)
- Ciclo di risciacquo con acqua durante l'avviamento (Modulari)
- Svuotamento acqua durante la fase di spegnimento (Modulari)
- Svuotamento evaporatore durante la fase di spegnimento (Modulari)
- Costi di esercizio ridotti, consumi di elettricità ed acqua bassi
- Ingombro ridotto
- Massima accessibilità alla componentistica
- Refrigerante R290/R452A

## Caractéristiques Générales

- Production continue
- Carrosserie en acier inoxydable (AISI 304)
- Refroidissement par air (A) ou par eau (W)
- KF85 avec ventilation frontale pour encastrement (Mod. F)
- Interrupteur général (ON/OFF)
- Transmission par courroie
- Contrôle électronique du fonctionnement (Modulaires)
- Filtre (Modulaires)
- Motoréducteur (Modulaires)
- Lavage à l'eau au début (Modulaires)
- Drainage de l'eau à l'arrêt (Modulaires)
- Déchargement de glace de l'évaporateur à l'arrêt (Modulaires)
- Réduits coûts d'exercice, réduite consommation d'électricité et d'eau
- Dimensions réduites
- Composants facilement accessibles
- Réfrigérant R290/R452A

## General Specifications

- Continuous production
- Stainless steel bodywork (BS 304 S01)
- Condensing units air cooled (A) or water cooled (W)
- KF85 with frontal ventilation for boxing in (Mod. F)
- Main switch (ON/OFF)
- Belt drive system
- Electronic function control (Modulars)
- Filter (Modulars)
- Direct driven system (Modulars)
- Rinsing with water at start (Modulars)
- Water drainage at stop (Modulars)
- Ice unloading of the evaporator at stop (Modulars)
- Low power and water consumption
- Reduced dimensions
- Maximum accessibility to components
- Refrigerant R290/R452A

## Características Generales

- Producción continua
- Carrocería en acero inoxidable (AISI 304)
- Condensación por aire (A) o por agua (W)
- KF85 con ventilación frontal bajo barra (Mod. F)
- Interruptor general (ON/OFF)
- Transmisión por correa
- Controles electrónicos de funcionamiento (Modulares)
- Filtro (Modulares)
- Motoreductor (Modulares)
- Enjuague con agua a la salida (Modulares)
- Drenaje del agua en la parada (Modulares)
- Descarga de hielo del evaporador en la parada (Modulares)
- Reducido coste de fabricación, consumos eléctricos y de agua bajos
- Dimensiones reducidas
- Máxima accesibilidad sobre los componentes
- Refrigerante R290/R452A

## Generelle Eigenschaften

- Kontinuierliche Eisproduktion
- Chromnickelstahl Gehäuse (AISI 304)
- Luftkühlung (A) oder Wasserkühlung (W)
- KF85 mit Frontbelüftung für den Einbau auf Anfrage (Mod. F)
- Hauptschalter (Ein/Aus)
- Keilriemenantrieb
- Elektronische Steuerung (Module)
- Filter (Module)
- Direktantrieb (Module)
- Spülen mit Wasser bei Start (Module)
- Ablassen des Wassers bei Stopp (Module)
- Entleeren des Verdampfers von Eis bei Stopp (Module)
- Reduzierte Betriebskosten durch eingeschränkten Strom- und Wasserverbrauch
- Reduzierte Ausmaße
- Leicht erreichbare Komponenten
- Kältemittel R290/R452A



### KFP 85

	A	W
Produzione • Production • Production Produccion • Tagesleistung	*Kg/24h Lb/24h	75 78 165 172
Capacità contenitore • Capacité bac • Bin capacity Capacidad del deposito • Behälterkapazität	Kg - Lb	25 - 55
Assorbimento • Consommation • Power Potencia • Leistungsaufnahme	(T=43°C)-W	400
Peso netto • Poids net • Net weight Peso neto • Nettogewicht	Kg	52
Peso lordo • Poids brut • Gross weight Peso bruto • Bruttogewicht	Kg	56
Volume con imballo • Volume emballage • Volume packing Volume con embalage • Verpackungsvolumen	m <sup>3</sup>	0,31
Refrigerante • Réfrigérant • Refrigerant Refrigerante • Kältemittel		R290
Voltaggio standard • Voltage standard • Standard voltage Voltage • Anschlußspannung		V230/50Hz/1

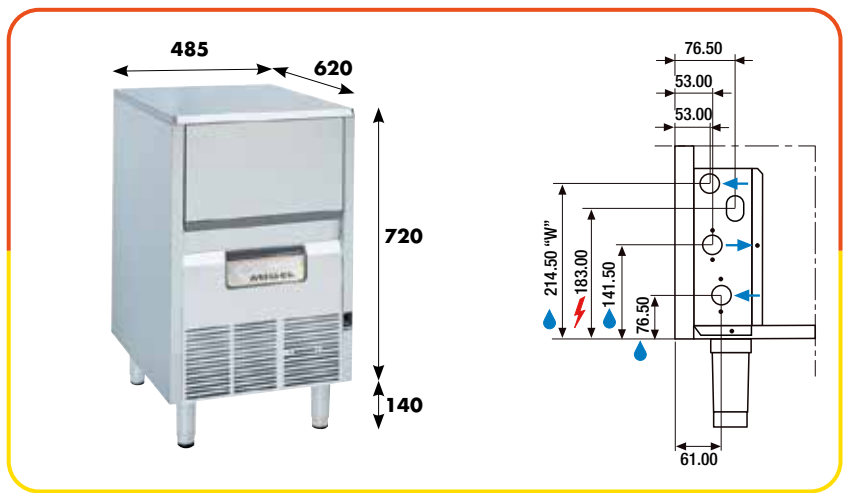

### KFP 145

	A	W
Produzione • Production • Production Produccion • Tagesleistung	*Kg/24h Lb/24h	120 125 264 275
Capacità contenitore • Capacité bac • Bin capacity Capacidad del deposito • Behälterkapazität	Kg - Lb	42 - 92
Assorbimento • Consommation • Power Potencia • Leistungsaufnahme	(T=43°C)-W	450
Peso netto • Poids net • Net weight Peso neto • Nettogewicht	Kg	69
Peso lordo • Poids brut • Gross weight Peso bruto • Bruttogewicht	Kg	74
Volume con imballo • Volume emballage • Volume packing Volume con embalage • Verpackungsvolumen	m <sup>3</sup>	0,52
Refrigerante • Réfrigérant • Refrigerant Refrigerante • Kältemittel		R290
Voltaggio standard • Voltage standard • Standard voltage Voltage • Anschlußspannung		V230/50Hz/1

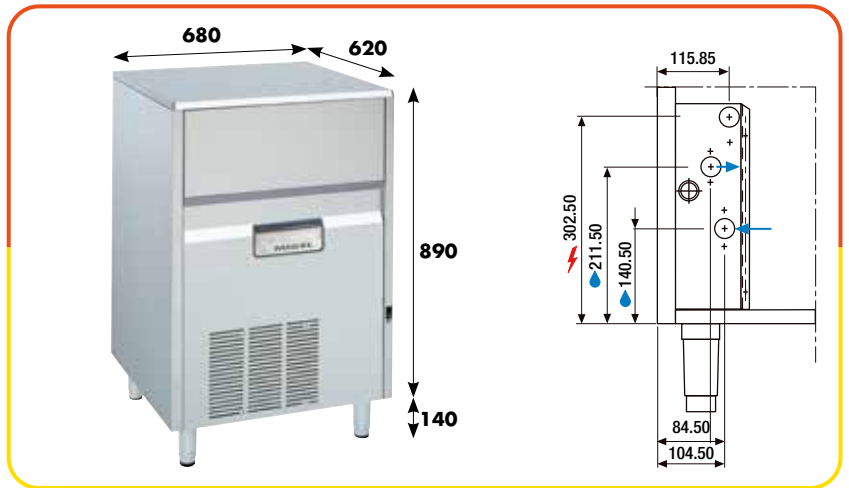

### KFP 185

	A	W
Produzione • Production • Production Produccion • Tagesleistung	*Kg/24h Lb/24h	165 170 363 374
Capacità contenitore • Capacité bac • Bin capacity Capacidad del deposito • Behälterkapazität	Kg - Lb	60 - 132
Assorbimento • Consommation • Power Potencia • Leistungsaufnahme	(T=43°C)-W	690
Peso netto • Poids net • Net weight Peso neto • Nettogewicht	Kg	85
Peso lordo • Poids brut • Gross weight Peso bruto • Bruttogewicht	Kg	91
Volume con imballo • Volume emballage • Volume packing Volume con embalage • Verpackungsvolumen	m <sup>3</sup>	0,63
Refrigerante • Réfrigérant • Refrigerant Refrigerante • Kältemittel		R290
Voltaggio standard • Voltage standard • Standard voltage Voltage • Anschlußspannung		V230/50Hz/1

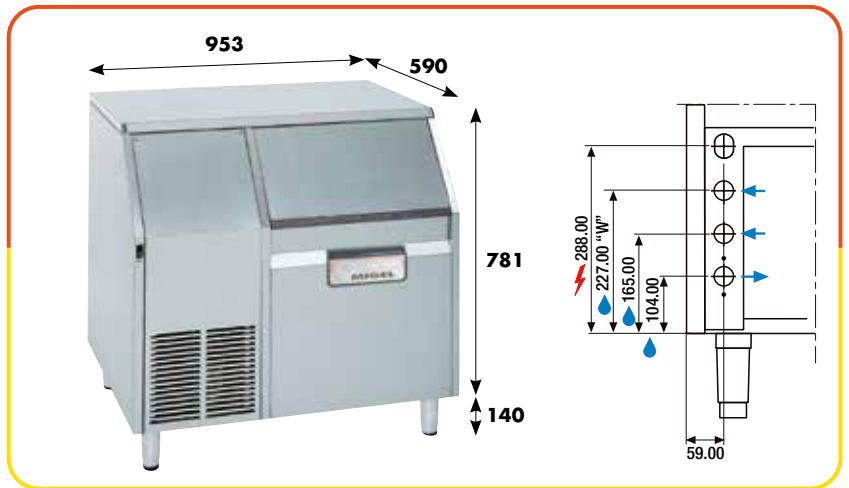

### KFP 200

	A	W
Produzione • Production • Production Produccion • Tagesleistung	*Kg/24h Lb/24h	175 180 385 396
Capacità contenitore • Capacité bac • Bin capacity Capacidad del deposito • Behälterkapazität	Kg - Lb	-
Assorbimento • Consommation • Power Potencia • Leistungsaufnahme	(T=43°C)-W	720
Peso netto • Poids net • Net weight Peso neto • Nettogewicht	Kg	60
Peso lordo • Poids brut • Gross weight Peso bruto • Bruttogewicht	Kg	68
Volume con imballo • Volume emballage • Volume packing Volume con embalage • Verpackungsvolumen	m <sup>3</sup>	0,49
Refrigerante • Réfrigérant • Refrigerant Refrigerante • Kältemittel		R290
Voltaggio standard • Voltage standard • Standard voltage Voltage • Anschlußspannung		V230/50Hz/1

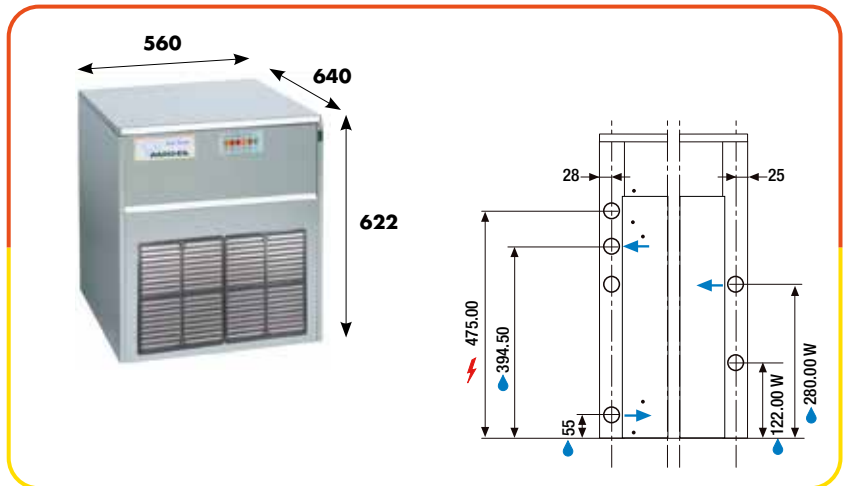



### KFP 300

	A	W
Produzione • Production • Production Produccion • Tagesleistung	*Kg/24h Lb/24h	270 275 594 605
Capacità contenitore • Capacité bac • Bin capacity Capacidad del deposito • Behälterkapazität	Kg - Lb	-
Assorbimento • Consommation • Power Potencia • Leistungsaufnahme	(T=43°C)-W	920
Peso netto • Poids net • Net weight Peso neto • Nettogewicht	Kg	69
Peso lordo • Poids brut • Gross weight Peso bruto • Bruttogewicht	Kg	75
Volume con imballo • Volume emballage • Volume packing Volume con embalage • Verpackungsvolumen	m <sup>3</sup>	0,49
Refrigerante • Réfrigérant • Refrigerant Refrigerante • Kältemittel		R290
Voltaggio standard • Voltage standard • Standard voltage Voltage • Anschlußspannung		V230/50Hz/1

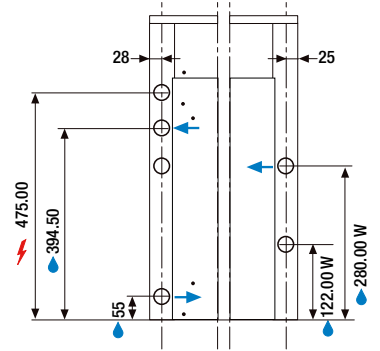

### KFP 600

	A	W
Produzione • Production • Production Produccion • Tagesleistung	*Kg/24h Lb/24h	475 475 1045 1045
Capacità contenitore • Capacité bac • Bin capacity Capacidad del deposito • Behälterkapazität	Kg - Lb	-
Assorbimento • Consommation • Power Potencia • Leistungsaufnahme	(T=43°C)-W	1950
Peso netto • Poids net • Net weight Peso neto • Nettogewicht	Kg	93
Peso lordo • Poids brut • Gross weight Peso bruto • Bruttogewicht	Kg	100
Volume con imballo • Volume emballage • Volume packing Volume con embalage • Verpackungsvolumen	m <sup>3</sup>	0,57
Refrigerante • Réfrigérant • Refrigerant Refrigerante • Kältemittel		R290
Voltaggio standard • Voltage standard • Standard voltage Voltage • Anschlußspannung		V230/50Hz/1

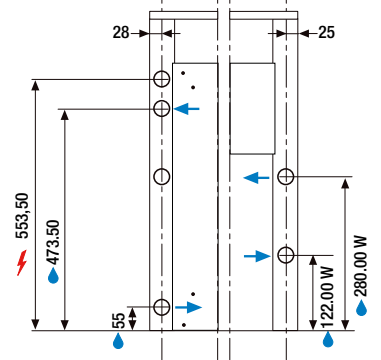

### KFP 1200

	A	W
Produzione • Production • Production Produccion • Tagesleistung	*Kg/24h Lb/24h	900 900 1980 1980
Capacità contenitore • Capacité bac • Bin capacity Capacidad del deposito • Behälterkapazität	Kg - Lb	-
Assorbimento • Consommation • Power Potencia • Leistungsaufnahme	(T=43°C)-W	3600
Peso netto • Poids net • Net weight Peso neto • Nettogewicht	Kg	153
Peso lordo • Poids brut • Gross weight Peso bruto • Bruttogewicht	Kg	161
Volume con imballo • Volume emballage • Volume packing Volume con embalage • Verpackungsvolumen	m <sup>3</sup>	0,90
Refrigerante • Réfrigérant • Refrigerant Refrigerante • Kältemittel		R452A
Voltaggio standard • Voltage standard • Standard voltage Voltage • Anschlußspannung		V400/50Hz/3N

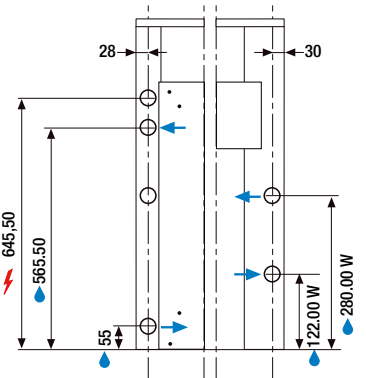

### KFP 2500

	A	W
Produzione • Production • Production Produccion • Tagesleistung	*Kg/24h Lb/24h	1700 1700 3740 3740
Capacità contenitore • Capacité bac • Bin capacity Capacidad del deposito • Behälterkapazität	Kg - Lb	-
Assorbimento • Consommation • Power Potencia • Leistungsaufnahme	(T=43°C)-W	2x3600
Peso netto • Poids net • Net weight Peso neto • Nettogewicht	Kg	295
Peso lordo • Poids brut • Gross weight Peso bruto • Bruttogewicht	Kg	318
Volume con imballo • Volume emballage • Volume packing Volume con embalage • Verpackungsvolumen	m <sup>3</sup>	1,40
Refrigerante • Réfrigérant • Refrigerant Refrigerante • Kältemittel		R452A
Voltaggio standard • Voltage standard • Standard voltage Voltage • Anschlußspannung		V400/50Hz/3N

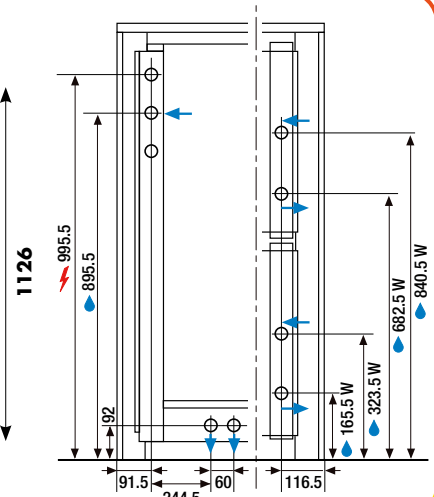



### TF 60/RB 60

	A	W
Capacità contenitore • Capacité bac • Bin capacity Capacidad del deposito • Behälterkapazität	Kg - Lb	60 - 132
Peso netto • Poids net • Net weight Peso neto • Nettogewicht	Kg	47
Peso lordo • Poids brut • Gross weight Peso bruto • Bruttogewicht	Kg	51
Volume con imballo • Volume emballage Volume packing • Volume con embalage Verpackungsvolumen	m <sup>3</sup>	0,41

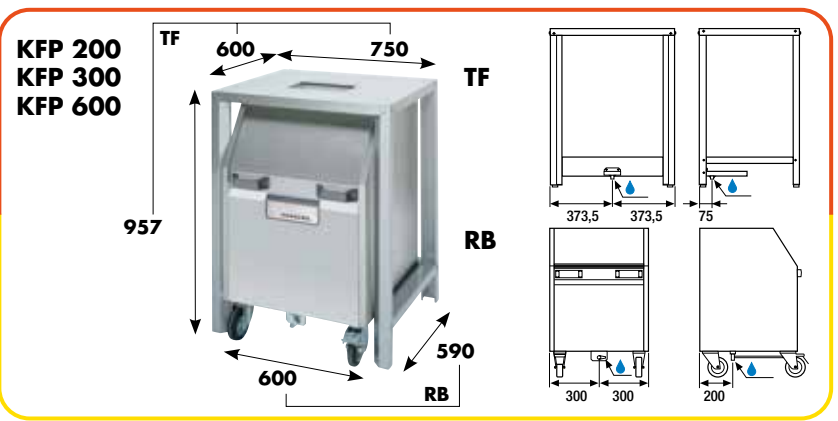

### TF 100/RB 100

	A	W
Capacità contenitore • Capacité bac • Bin capacity Capacidad del deposito • Behälterkapazität	Kg - Lb	100 - 220
Peso netto • Poids net • Net weight Peso neto • Nettogewicht	Kg	57
Peso lordo • Poids brut • Gross weight Peso bruto • Bruttogewicht	Kg	61
Volume con imballo • Volume emballage Volume packing • Volume con embalage Verpackungsvolumen	m <sup>3</sup>	0,54

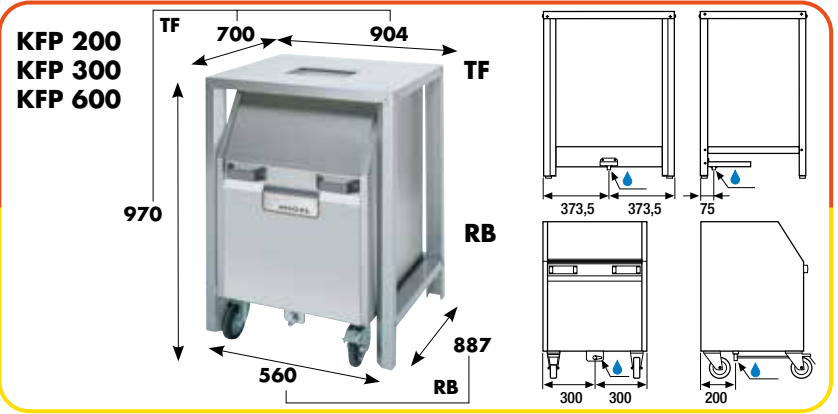

### B 100/BF 100

	A	W
Capacità contenitore • Capacité bac • Bin capacity Capacidad del deposito • Behälterkapazität	Kg - Lb	100 - 220
Peso netto • Poids net • Net weight Peso neto • Nettogewicht	Kg	31
Peso lordo • Poids brut • Gross weight Peso bruto • Bruttogewicht	Kg	38
Volume con imballo • Volume emballage Volume packing • Volume con embalage Verpackungsvolumen	m <sup>3</sup>	0,54

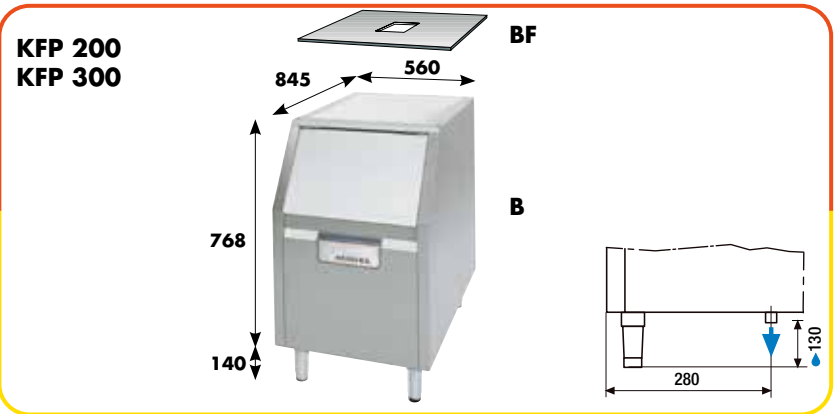

### B 150/BF 150

	A	W
Capacità contenitore • Capacité bac • Bin capacity Capacidad del deposito • Behälterkapazität	Kg - Lb	150 - 330
Peso netto • Poids net • Net weight Peso neto • Nettogewicht	Kg	49
Peso lordo • Poids brut • Gross weight Peso bruto • Bruttogewicht	Kg	55
Volume con imballo • Volume emballage Volume packing • Volume con embalage Verpackungsvolumen	m <sup>3</sup>	0,90

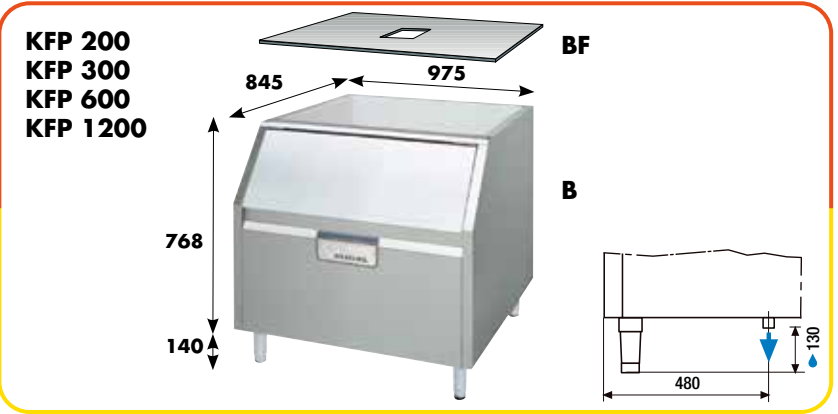

### B 250/BF 250

	A	W
Capacità contenitore • Capacité bac • Bin capacity Capacidad del deposito • Behälterkapazität	Kg - Lb	250 - 550
Peso netto • Poids net • Net weight Peso neto • Nettogewicht	Kg	62
Peso lordo • Poids brut • Gross weight Peso bruto • Bruttogewicht	Kg	68
Volume con imballo • Volume emballage Volume packing • Volume con embalage Verpackungsvolumen	m <sup>3</sup>	1,09

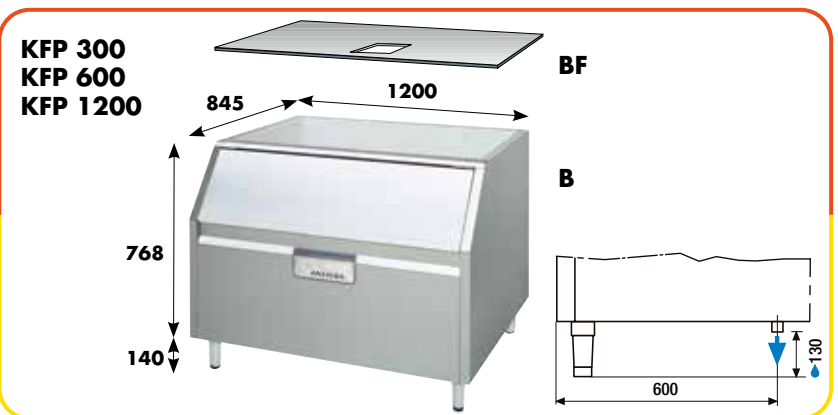

# MIGEL KFP

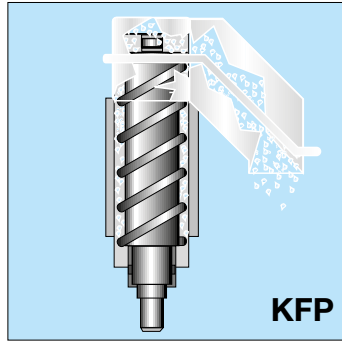

## FILTER

a richiesta KF 45/85/145/185  
sur demande KF 45/85/145/185  
on request KF 45/85/145/185  
a petición KF 45/85/145/185  
auf Anfrage KF 45/85/145/185



## KFP 85

a richiesta • sur demande • on request  
a petición • auf Anfrage



### Attenzione:

Le produzioni nelle 24h si intendono ad una temperatura ambiente +10°C e una temperatura acqua +10°C. Il voltaggio standard è V230/50Hz monofase. Altri voltaggi come V230/60Hz e V115/60Hz monofase a richiesta.

I modelli e le caratteristiche possono subire modifiche senza preavviso.

### Attention:

Les productions dans les 24 heures s'entendent à une température ambiante de +10°C et à une température de l'eau de +10°C. Le voltage standard est de 230V/50Hz monophasé.

Sur demande, possibilité de fourniture d'autres voltages comme le 230V/50Hz et le 115V/60Hz monophasé. Les modèles et les caractéristiques peuvent subir des modifications sans préavis.

### Important:

24h production is intended at an ambient temperature of +10°C with a water temperature of +10°C. Standard voltage is V230/50Hz single phase. Other voltages such as V230/60Hz and V115/60Hz single phase on request. Models and specifications may be subject to variations without prior notice.

### Atención:

Las producciones en las 24h se consideran con una temperatura ambiente de +10°C y una temperatura del agua de +10°C. El voltaje estándar es V230/50Hz monofásico. Otros voltajes como V230/60Hz y V115/60Hz monofásico a petición.

Los modelos y las características pueden sufrir variaciones sin aviso previo.

### Achtung:

Die Produktion innerhalb von 24 Stunden versteht sich bei einer Raumtemperatur von +10°C sowie einer Wassertemperatur von +10°C. Die Standardspannung beträgt V230/50Hz einphasig. Weitere Spannungswerte wie V230/60Hz und V115/60 Hz einphasig auf Anfrage. Die Modelle und Charakteristiken können Änderungen ohne Vorankündigung unterliegen.



Migel S.r.l. Viale Risorgimento, 28 - I - 20030 Senago (MI)  
Tel. (+39) 02 99057727 - Fax (+39) 02 99056470 - e-mail: migel@migel-ice-line.com  
www.migel-ice-line.com